

EN 22858
EN 25199

RD-RG

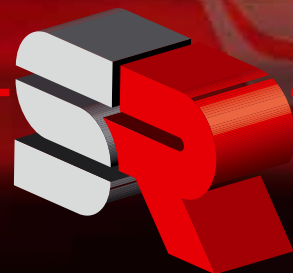

**GIRANTE CHIUSA E APERTA
CLOSED AND OPEN IMPELLER**



**SALVATORE
ROBUSCHI
POMPE PARMA**

RD



ISO 2858 - 5199
UNI EN 22858 - 25199



RG

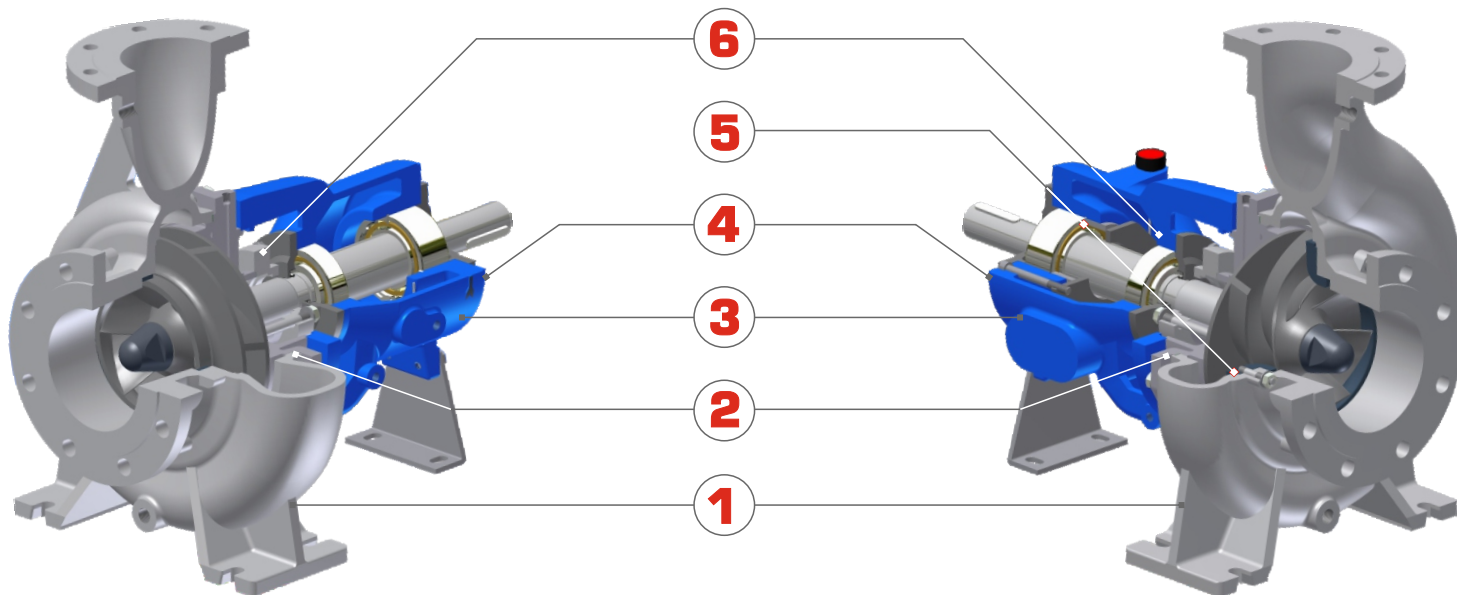

La gamma comprende pompe centrifughe a girante chiusa [RD] e girante aperta [RG] entrambe unificate con parte idraulica secondo la normativa chimica EN 22858 e parte meccanica secondo EN 25199 che definisce le massime flessioni d'albero, la resistenza meccanica e la durata minima dei cuscinetti. Oltre alla scontata efficienza, gli obiettivi primi di questa serie sono di offrire modularità delle parti meccaniche, intercambiabilità e grande scelta nei sistemi di tenuta, intercambiabilità delle idrauliche (giranti aperte e chiuse sullo stesso corpo pompa) e bassi NPSH. Questo consente di impiegare queste macchine dalle applicazioni più semplici con liquidi aggressivi fino alle più complesse con solidi in sospensione, alte temperature, viscosità e pesi specifici. La pressione di esercizio è 16 BAR per uso con liquidi corrosivi e 20 BAR con liquidi non aggressivi. Gli spessori dei corpi e dei coperchi sono maggiorati di 3 mm per la corrosione secondo la normativa.



- **NORME:** EN 22858 - 25199 - PN 16
- **MODULARITA':** 3 gruppi supporto-albero per 35 grandezze.
- **RENDIMENTI:**
 - ⇒ giranti microfuse per alti rendimenti.
 - ⇒ le giranti aperte hanno rendimenti appena al di sotto delle chiuse.
- **VERSATILITA':** due tipi di giranti nello stesso corpo e 12 varianti di sede tenuta nello stesso coperchio.
- **USO:** giranti chiuse per liquidi limpidi e giranti aperte per solidi non abrasivi, liquidi con gas disciolti e condizioni di aspirazione critiche.
- **MATERIALI:**
 - ⇒ standard AISI 316 con camicia e sede tenuta in AISI 316L
 - ⇒ DUPLEX con parti da barra in SAF 2205)
 - ⇒ SUPERDUPLEX con parti da barra in SAF 2507)
 - ⇒ AISI 304 L
 - ⇒ AISI 904L
 - ⇒ SANICRO 28
 - ⇒ HASTELLOY B e C
 - ⇒ CAGNM con durezza 400 Brinell
 - ⇒ ALTRE LEGHE a richiesta



This range includes centrifugal pumps with closed impeller [RD] type and open impeller [RG] type, both unified with the hydraulic part according to the EN 22858 chemical rule and the mechanical one according to EN 25199, which defines the max. shaft deflection, mechanical resistance and ball bearings' minimum life. The main aspects of this series are mechanical parts modularity, interchangeability, wide sealing systems' choice, but also hydraulic design interchangeability (open and closed impellers mounted on the same pump casing) and low NPSH values. This allows to use these pumps from the easiest applications with aggressive liquids to the most difficult applications with suspended solids, high temperatures, high viscosity and specific gravity. Max. operating pressure is 16BAR, but it can reach 20 BAR, when used for not aggressive liquids.



- **RULES:** EN 22858 - 25199 - PN 16
- **MODULARITY:** 3 bearing housing- shaft groups for 35 sizes.
- **EFFICIENCY:**
 - ⇒ investment casting impellers for high efficiency.
 - ⇒ open impellers have efficiency similar to closed impellers.
- **FLEXIBILITY:** 2 impeller types can be installed in the same casing and 14 different seals systems can be fitted in the same casing cover.
- **USE:** closed impellers for clean liquids, open impellers for not abrasive solids, liquids with dissolved gases and critical suction conditions.
- **MATERIALS:**
 - ⇒ standard is AISI 316 with sleeve and seal seat in AISI 316L
 - ⇒ DUPLEX with parts in SAF 2205)
 - ⇒ SUPERDUPLEX with parts in SAF 2507)
 - ⇒ AISI 304 L
 - ⇒ AISI 904L
 - ⇒ SANICRO 28
 - ⇒ HASTELLOY B and C
 - ⇒ CAGNM wear resistant material, 400 Brinell hardness
 - ⇒ Further ALLOYS on demand

1 SOLO CORPO, 2 giranti - 1 CASING, 2 impellers

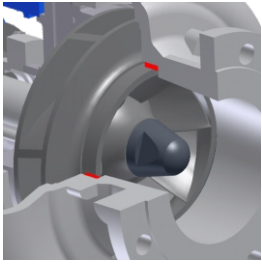

OGNI GRANDEZZA HA UN SOLO CORPO che può essere utilizzato per la girante chiusa (con collare d'usura) e girante aperta (con piastra di usura sostituibile). Questo consente, con semplici operazioni, di adattare la pompa a nuove esigenze d'impianto e processo.



ONLY ONE CASING EVERY SIZE. It can be used both for closed impeller (with wearing ring) and open impeller (with replaceable wearing plate): just with a few changes the pump can be adapted to new plant and process requirements.

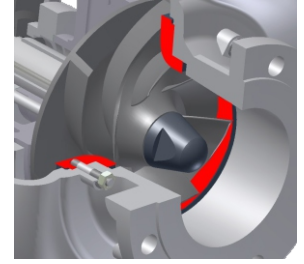

2 SOLO COPERCHIO, 14 sistemi di tenuta - 1 CASING COVER, 14 seal systems



OGNI GRANDEZZA HA UN SOLO COPERCHIO che può ospitare qualsiasi tipo, marca e soluzione di tenuta (vedi punto 6). La cassa stoppa, di tipo cilindrico, ha diametri superiori a quelli raccomandati dalla normativa per garantire la massima circolazione di liquido. I diversi alloggiamenti sono ottenuti con l'utilizzo di soli componenti per cui è possibile in qualsiasi momento passare da una conformazione all'altra, ad esempio da singola a doppia, baderna o cartuccia, con la semplice sostituzione di alcune parti. Oltre a ridurre la scorta di ricambi, questo sistema consente di adattare velocemente ed economicamente la pompa alle nuove esigenze d'impianto.

ONLY ONE CASING COVER FOR EVERY SIZE. It can fit every seal type, brand and seal arrangement (see section 6).

The seal chamber, which is cylindrical, has diameters bigger than those suggested by the rule, to grant the best circulation of liquid. Different seal seat types can be obtained using few components, so it is always possible to change from an execution to another one: for example from single mechanical seal to double mechanical seal or packing-gland or cartridge, just replacing some components. In this way it is easy to modify the pump for new plant requirements in a fast and cheap way. Besides, this modular system allows to have in stock only few spares to cover the whole pump range.

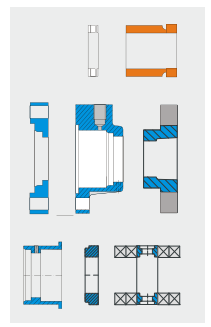

3 SUPPORTO HEAVY DUTY- HEAVY DUTY BEARING

ISO 5199 - EN 25199

SUPPORTO UNIFICATO: Pompe a girante chiusa, aperta, canali e arretrata utilizzano lo stesso supporto. La costruzione secondo EN 25199, oltre a garantire flessioni d'albero < 0,05 mm e un minimo di 18.000 ore di funzionamento, è studiata per ripartire i carichi assiali e radiali al fine di ridurre drasticamente le temperature di esercizio. Tutti i supporti sono predisposti per ospitare la versione pesante «HD1» con cuscinetti serie 7000 combinati con cuscinetto a rulli. La serie contempla anche supporti maggiorati per funzionamento fino a 100.000 ore.

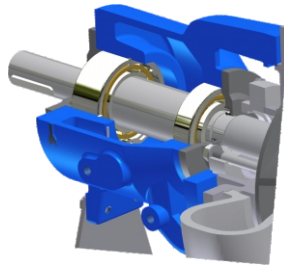

A UNIFIED BEARING HOUSING: The same bearing housing can be used for pumps with closed, open, channel, vortex impellers. Building according to EN 25199, which ensures shaft deflection < 0,05 mm and min. 18.000 operation hours, has been designed also to balance axial and radial loads, to reduce working temperatures. Bearing housings are suitable to seat the heavy duty execution called «HD1» with ball bearings series 7000, combined with roller bearings. The series also include bigger bearing housings to work up to 100.000 hours.

4 ESECUZIONE MODULARE - MODULAR EXECUTION

MANUTENZIONE FACILE: 3 supporti e 6 lanterne, sono sufficienti per costruire l'intera gamma nelle versioni monoblocco, lanternata e su base. I basamenti sono sovradimensionati per garantire stabilità. La versione lanternata elimina i problemi di disallineamento tra pompa e motore.

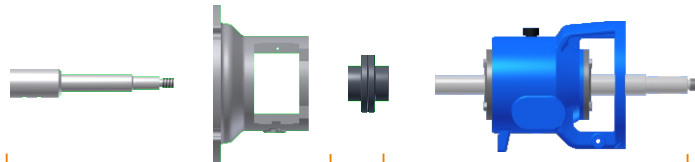

EASY MAINTENANCE: to build the whole pumps range (close-coupled, lantern bracket and on base plate execution) are necessary just 3 bearing housings and 6 lanterns. Oversized base-plates grant high stability; the lantern bracket execution avoids problems related to misalignment between pump and motor.

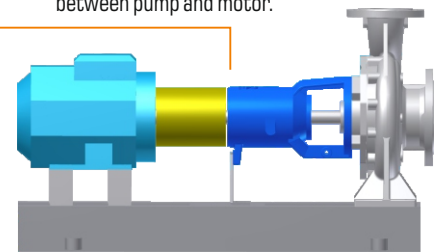
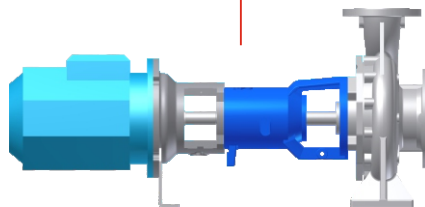
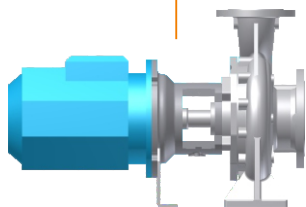

5 PIASTRA DI USURA E REGISTRAZIONE - WEARING PLATE AND ADJUSTMENT

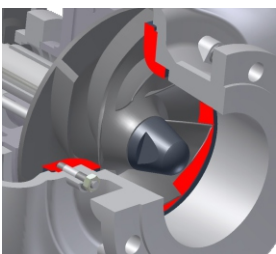

La PIASTRA DI USURA SOSTITUIBILE garantisce lunga vita alla pompa e riduce i costi di manutenzione. Inoltre il supporto è dotato di REGISTRAZIONE ASSIALE dei GIOCHI, che possono essere variati operando da lato comando.

THE REPLACEABLE WEARINGPLATE ensures long lasting to the pump and reduces maintenance costs. Furthermore bearing housing allows AXIAL CLEARANCES ADJUSTMENT operating by drive side.

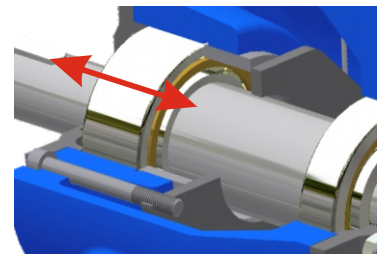

6 TENUTE: tutto in una sola camera- SEALS: one chamber, all seal systems

M single seal - standard

■ Tenuta meccanica singola auto lubrificata

■ Self lubricated single mechanical seal

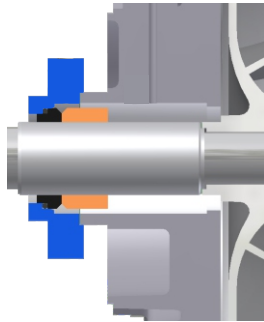

K cartridge seal

■ La camera standard è abbastanza grande da ospitare quasi tutti i tipi di cartuccia in commercio.

■ Standard seal chamber is big enough to seat almost all the cartridges on the market

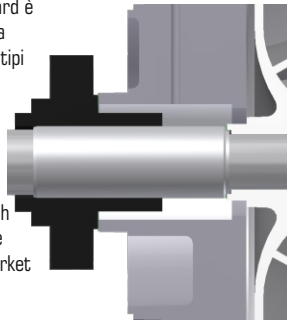

H heating / cooling chamber

■ La camera di raffreddamento o riscaldamento si può installare facilmente su tutte le pompe della serie RD - RG

■ The heating or cooling chamber can be easily installed on all RD-RG pumps

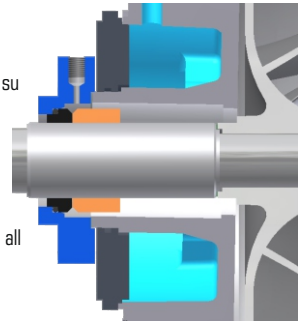

A single seal + bottom ring

■ da abbinare a PLAN 11 dalla mandata o PLAN 32 da fonte esterna. Disponibile anche versione «E» senza anello di fondo.

■ To use combined with PLAN 11 from the discharge or PLAN 32 from external circuit. Also available «E» execution without bottom ring.

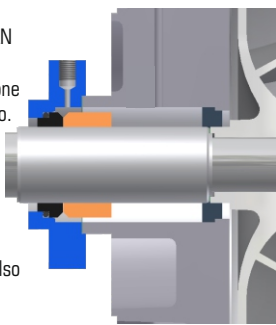

T single seal + pumping ring + bottom ring

■ Da utilizzare con liquidi molto caldi o surriscaldati in combinazione con scambiatore di calore esterno. PLAN 23

■ To use with hot or over-heated liquids and in combination with external heat exchanger. PLAN 23

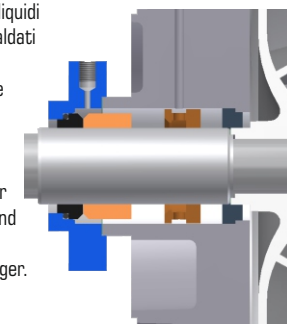

Q single seal + quench

■ Quench utilizzato principalmente per barriera vapore

■ Quench mainly used for steam barrier

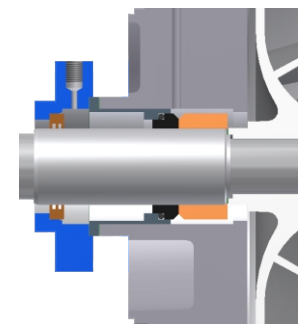

W single seal + self lubric. lip seal quench

■ tenuta combinata, per uso a secco senza liquidi ausiliari o con flussaggi discontinui. Barriera di sicurezza per liquidi pericolosi o zone ATEX

■ combined seal, for dry running without auxiliary liquids or for discontinuous flushing. Safety barrier for hazardous liquids or ATEX zones.

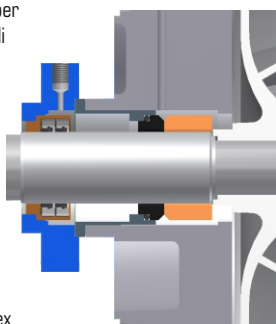

U single seal close to the impeller

■ tenuta singola per liquidi sporchi o viscosi. La posizione vicina alla girante favorisce la lubrificazione.

■ Single seal for dirty or viscous liquids. its position, close to the impeller, facilitates lubrication.

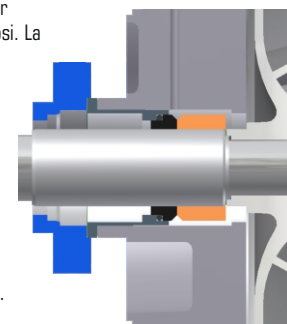

S gland packing with hydraulic barrier

■ tenuta a baderna con anello idraulico di sbarramento e flussaggio. Disponibile anche versione «B» senza anello.

■ gland packing seal with barrier hydraulic ring and flushing. Also available «B» execution without ring.

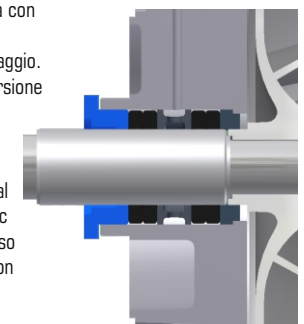

L double tandem mechanical seal

■ tenuta doppia in tandem. PLAN 52. Disponibile anche foro di lavaggio per tenuta lato prodotto

■ double tandem mechanical seal. PLAN 52. Also available washing connection for the pump side seal.

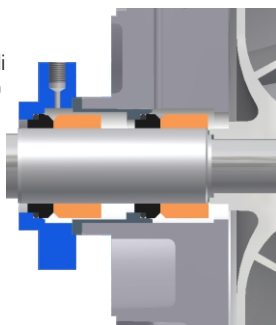

C double back to back mechanical seal

■ tenuta doppia contrapposta. PLAN 53 - PLAN 54

■ double back to back seal. PLAN 53 - PLAN 54

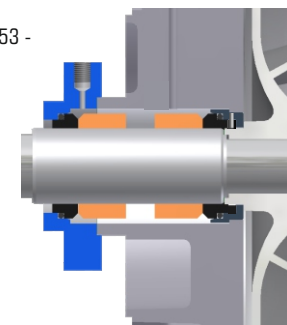

P double back to back seal + pumping ring

■ tenuta doppia contrapposta con pumping ring. PLAN 53 - PLAN 54

■ double back to back seal with pumping ring. PLAN 53 - PLAN 54

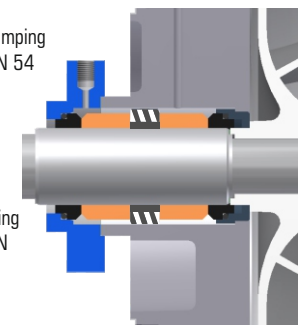

V self lubricated lip seal

■ tenuta ad anelli auto-lubrificati per liquidi puliti e viscosi. Disponibile anche su camicia ceramizzata.

■ self-lubricated seal rings suitable for clean and viscous liquids. Also available on ceramized shaft sleeve.

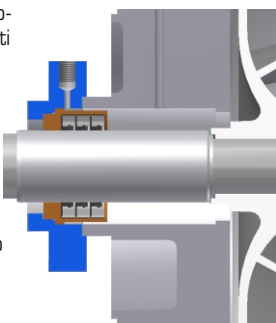

J lip seal + quench + heating chamb.

■ come versione «V», ma con quench a baderna di sicurezza e camera di riscaldamento.

■ as «V» type, but with safety gland packing quench and heating chamber.

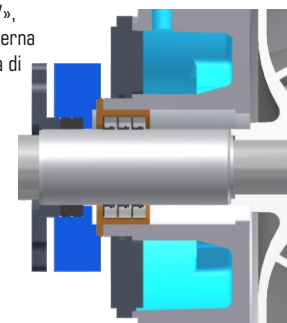

+ Vessels, self cooled system etc...

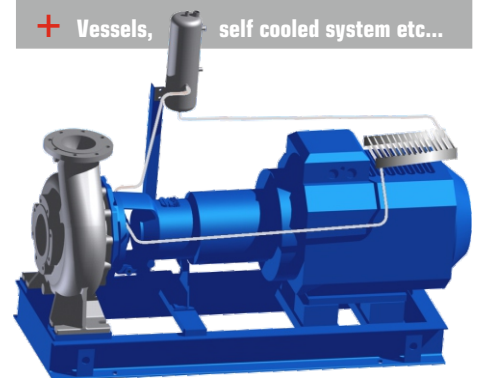



Per aggiornamenti sui nostri prodotti visitate il nostro sito:
For updates on our products, you can visit our website:

www.srpumps.com
www.salvatorerobuschi.com
com@salvatorerobuschi.com



Salvatore Robuschi & C. S.r.l.
Via Segrè 11/a
43122 Parma • Italy
Tel. +39 (0)521.606285
Fax +39 (0)521.606278